

GLC SUV



X253

Model Year 2020

Preliminary – Subject to Change

Mercedes-Benz

The best or nothing.





Important note

The information presented in this guide is based on the most current information available and is intended for internal use only. Mercedes-Benz reserves the right to make changes at any time, without notice, to colors, materials, equipment, special specifications and models.

Pricing may not yet be finalized for some models or options.

Due to variances among monitors and printers the colors that appear on your screen and printouts may not be exact.

For illustrative purposes, some images may show vehicles with European Specification.

Revision History

<i>Date</i>	<i>Changes</i>
2/28/2019	Initial publication
3/14/2019	Made minor updates and added pictures
3/22/2019	Updated new codes for VPC options
4/16/2019	Moved Rear Cross-Traffic Alert into the Parking Assistance Package (DA3)
5/1/2019	<ul style="list-style-type: none"> - Removed KEYLESS-GO (889) from Premium Package (DP1) - Removed HANDS-FREE ACCESS (P17) from Parking Assistance Package (DA3) - HANDS-FREE ACCESS (P17) requires KEYLESS-GO (889) - Parking Assistance Package (DA3) no longer requires Premium Package (DP1)
5/2/2019	<ul style="list-style-type: none"> - Added package prices (still preliminary) - Removed 736 trim (DD1 packages now uses 737+739 only) - Made minor edits for clarity
5/6/2019	<ul style="list-style-type: none"> - Put KEYLESS-GO (889) back into Premium Package (DP1) - Put HANDS-FREE ACCESS (P17) back into Parking Assistance Package (DA3) - Plausibility rules restored
5/8/2019	GLC63 information now included
5/15/2019	Updated pricing for Mercedes-Benz and Mercedes-AMG models
6/7/2019	<ul style="list-style-type: none"> - 77B option removed from offering on all models - Emergency Spare Wheel (690) not offered for GLC350E4 (corrected) - Updated prices on options for non-AMG models
6/25/2019	- GLC350E4 information now included



Insert Models



Models



Interior Trims



What's new



Option Packages



Standard Equipment



Stand-Alone Options



Exterior Paint Colors



Options in Detail



Wheels

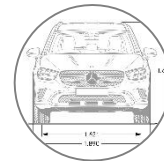

Specifications



Interior Upholstery



GLC 300 (253.983)

GLC300W

- MSRP \$42,500
- 2.0-L inline-4 turbo engine
- 9-Speed Automatic Transmission
- 255 hp
- 273 lb-ft
- TBD sec (0-60 mph)
- Launch date: Fall 2019



GLC 300 4MATIC (253.984)

GLC300W4

- MSRP \$44,500
- 2.0-L inline-4 turbo engine
- 9-Speed Automatic Transmission
- 255 hp
- 273 lb-ft
- TBD sec (0-60 mph)
- Launch date: Fall 2019



EQ POWER

GLC 350e 4MATIC Plug-in Hybrid (253.953) GLC350E4

- **MSRP \$TBD**
- 2.0L inline-4 turbo engine with 90kW electric motor
- 9-Speed Automatic Transmission
- 315 hp (combined)
- 516 lb-ft (combined)
- TBD sec (0-60 mph)
- Launch date: Fall 2019

***Price shown does not include \$X,XXX Federal Tax Credit (for purchase) or \$X,XXX bonus cash (for leased vehicles).**

Buyers and Lessees in certain states may receive additional incentives. For more information on the tax benefits of owning a Plug-in Hybrid vehicle, visit the U.S. Department of Energy website and consult with your financial advisor





Performance & Handling

- New M264 2.0L Inline-4 Turbocharged Engine with power output increase +14hp to 255 hp

Standard Equipment

- Smartphone Integration (Apple CarPlay™, Android Auto) becomes standard
- LED Headlamps & Taillamps become standard
- Updated steering wheel w/ haptic feedback touchpads and cruise control buttons
- Next-Generation Infotainment System “MBUX” now standard incl. “Hey Mercedes”
- New key design
- SD-Card Pre-Wiring removed from standard equipment
- 10.25” Center Touchscreen now available and is standard
- Blind Spot Assist (234) now standard

Optional Equipment

- LED Intelligent Light System available in Exterior Lighting Package
- 64-Color Ambient Lighting now available and added to Premium Package
- Augmented Video for Navigation (U19) now available in Multimedia Package
- Emergency Spare Wheel (690) now available as a standalone option
- Ski & Snowboard Bag (282) discontinued
- 12.3” Digital Instrument Panel available
- Inductive Wireless Charging and NFC Pairing (897) added as standalone option
- Next generation Driver Assistance technology available in Driver Assistance Package
- AMG Line receives Diamond Grille w/ single lamella
- Leather Package (318) deleted
- Passenger Seat Memory w/ Adjustable Thigh Support now a standalone option (242)

Interior Upholstery

- 234 Saddle Brown Leather discontinued
- P87 *designo* Black Leather discontinued.
- Espresso Brown (114 MB-TeX and 224 Leather) discontinued
- Magma Grey (128 MB-TeX & 228 Leather) now available
- AMG Line Cranberry Red (197 MB-TeX & 297 Leather) now available
- AMG Line Saddle Brown (164 MB-TeX & 264 Leather) now available

Trims

- Light Brown Linden Wood (H24) discontinued.
- Natural Grain Walnut Wood Trim (H33) now available
- Natural Grain Grey Oak Wood Trim (H31) now available





Paints

- Graphite Grey Metallic (831) now available
- Selenite Grey Magno (297) now available on GLC 300

Wheels

- New standard 18" Split 5-Spoke Wheels (97R)
- 20" 5-Spoke Wheels with Black Accents (29R) discontinued
- 19" AMG Split 5-Spoke wheels (638) discontinued
- 19" AMG Split 5-Spoke wheels with Black Accents (99R) discontinued
- New 19" 10-Spoke Alloy Wheels (R58) now available
- New 20" Split 5-Spoke Wheels (30R) now available
- New 19" AMG Split 5-Spoke Wheels (RTF) now available
- New 19" AMG Split 5-Spoke Wheels with Black Accents (RTG) now available
- New 20" AMG Y 5-Spoke Wheels (RZX) now available
- New 18" Aero Alloy Wheel (64R) now available (GLC350E4 only)
- New 19" Aero Alloy Wheel (15R) now available (GLC350E4 only)



Exterior Comparison MY19 (X253) vs. MY20 (X253)



European picture shown – wheels n/a in US

Interior Comparison MY19 (X253) vs. MY20 (X253)



Picture shows optional Equipment



Options shown: 264 Saddle Brown Leather, H33 Natural Grain Walnut Wood Trim, 464 Digital Instrument Cluster (optional), 810 Burmester Surround Sound System, and DG3 AMG Line elements shown.



Exterior Highlights



MB Exterior
Standard



AMG Line
DG3





Blind Spot Assist (234)

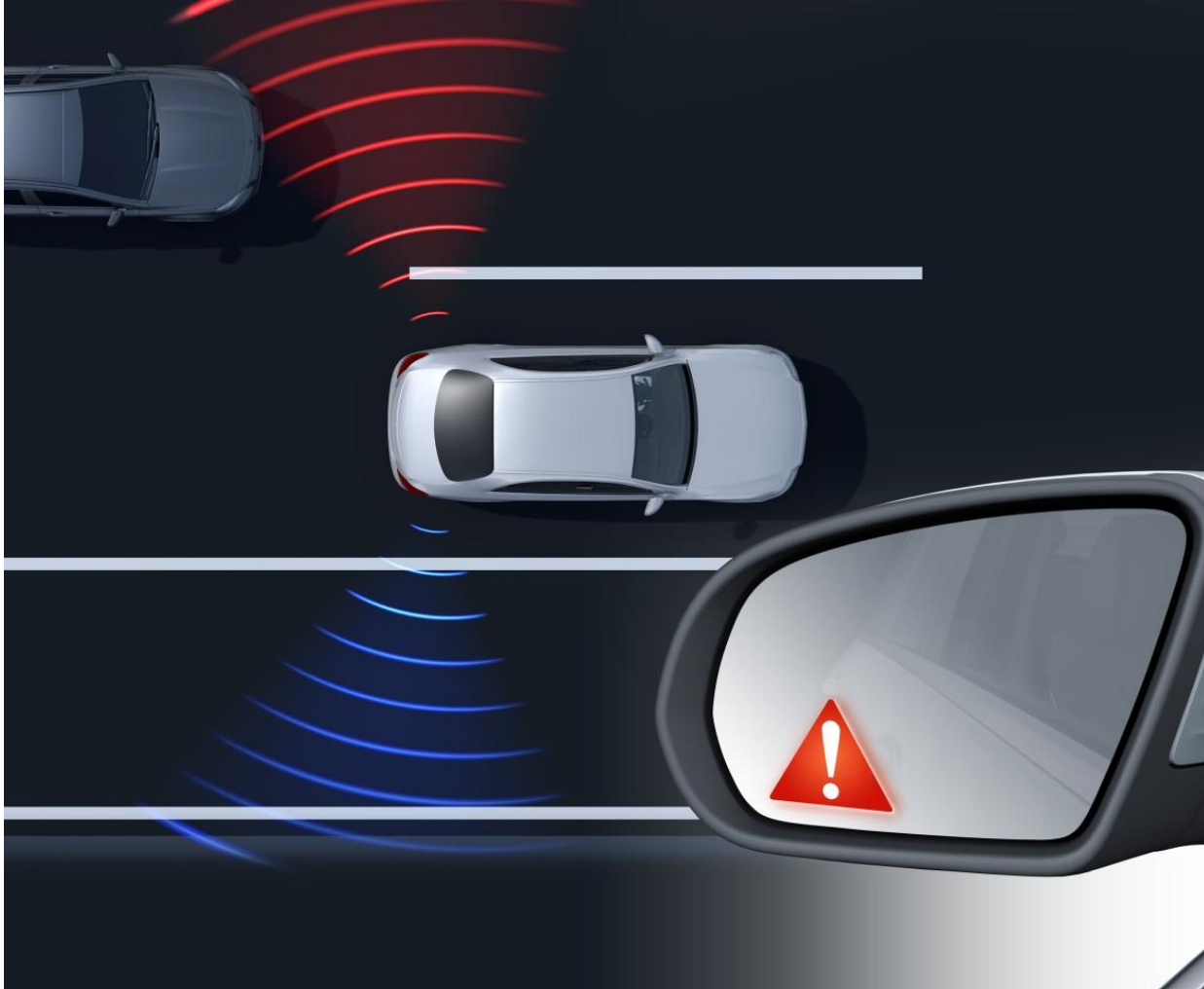

Blind Spot Assist (234)

Now standard

As a leader in safety innovation since the beginning of the automobile, Mercedes-Benz now offers the 2020 GLC with Blind Spot Assist as a standard feature. The vehicle will give visual and auditory indicator when a vehicle is in the blind spot. If the driver uses the turn indicator to make a lane change with a vehicle in the blind spot, the system will give an feedback sound that it is not safe to move into the lane.



Mercedes-Benz User Experience (MBUX)

MBUX - the newest head-unit generation from Mercedes-Benz

Standard

- MBUX was designed for a touch interface with intuitive operation
- There are four ways of interacting with the system:
 - An all-new Touchpad, Touch Control Buttons on the steering wheel, a touchscreen center display, and an all-new generation of Voice Control
- Multiple users can set up profiles which save their settings for future use
 - Including: seat settings, music preferences and radio settings, phone settings, themes/moods, Bluetooth connections, etc.
- Over time, the system learns more about its owners and creates suggestions based on past behavior of the user
- Whole groups of settings can be saved together in the form of a Theme/Mood
 - Including: ambient lighting, climate control, music preferences, and setup of the Digital Instrument Cluster and head unit display, etc.
- Using over-the-air updates, MBUX can continuously be improved over time
- The system is very quick and responsive due to its impressive graphics processing and computing power



Voice Control

One of the most advanced Voice Control systems in the industry

Standard

- Voice Control with MBUX is greatly enhanced over other systems by using both an onboard and offboard system for voice recognition
 - This ensures quick and appropriate responses
- The system also uses Natural Language Understanding so there's no need to remember the order of words for a specific command, just talk to the voice assistant as you would speak to another person
 - There are many ways of saying the same thing: *"Take me to Starbucks"*, or *"Find a Starbucks nearby"*, or *"Is there a Starbucks close?"*, or even *"I need a coffee"*
- Indirect commands can also be given like *"Will I need an umbrella today?"* and the Voice Control system understands that the user is really asking whether it will rain today
- In-vehicle components can also be controlled via Voice Control, like seat heating, climate control, ambient lighting, massage programs, and even the sunshade for the Panorama roof
- Voice Control is also capable of learning from its users and adjusting its understanding to their specific way of speaking
- Keyword Activation ensures you can quickly interact with Voice Control without having to press the button on the steering wheel
 - The system wakes up with a simple *"Hey Mercedes"*

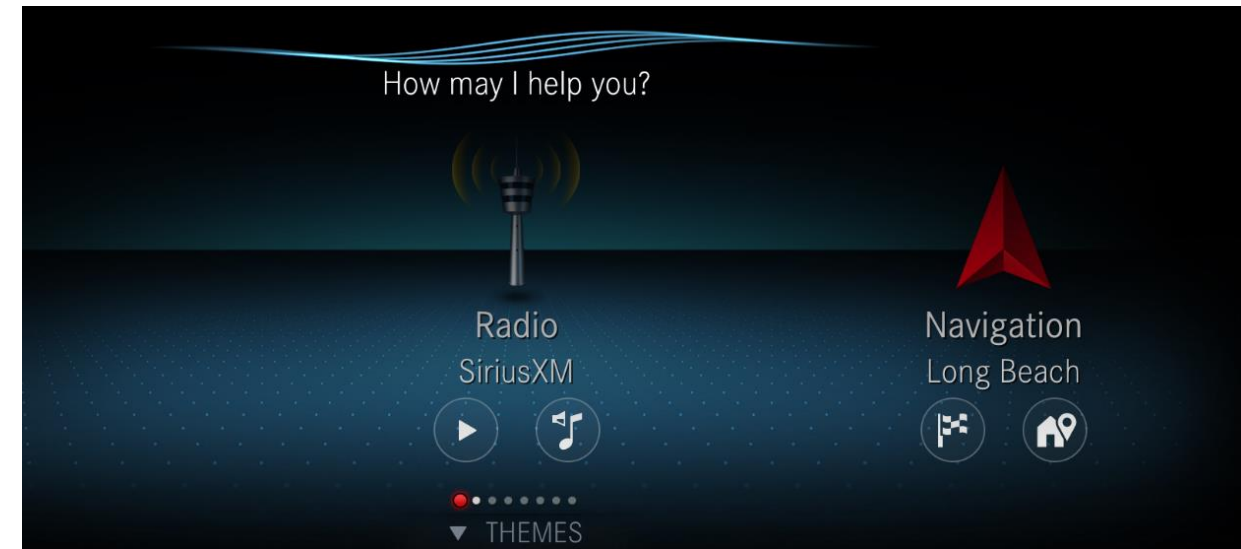



PRE-SAFE Sound

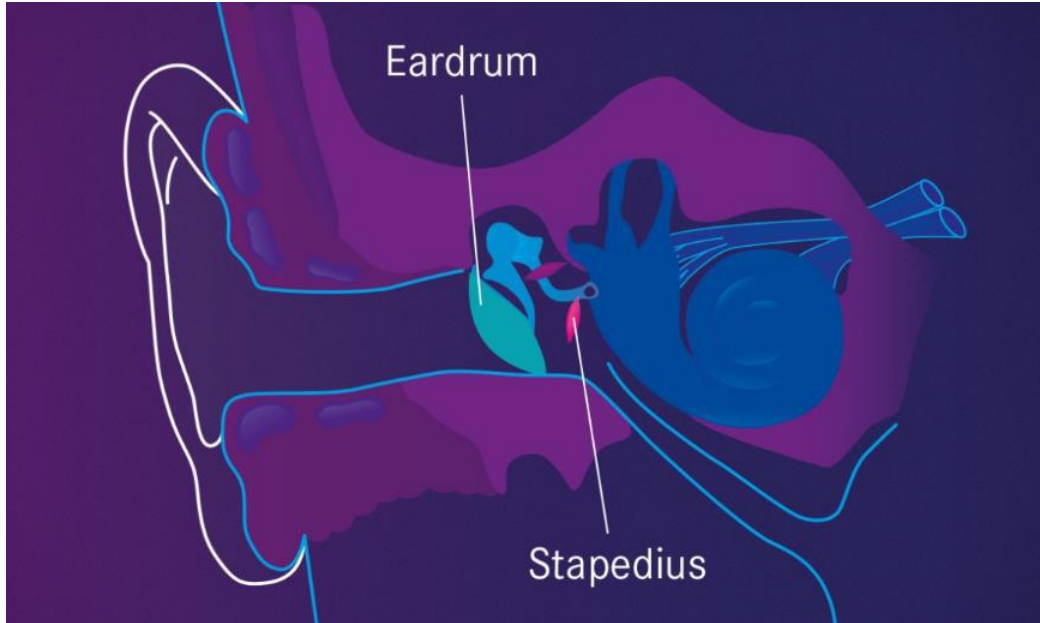

PRE-SAFE® Sound

Standard

Part of PRE-SAFE, PRE-SAFE Sound is an acoustic occupant preconditioning system which can reduce the effects of the noise from an accident on the occupants hearing.

- When the PRE-SAFE system recognizes a certain dangerous situation, the onboard sound system plays a brief rushing sound, also known as 'Pink Noise,' to precondition the hearing
- The natural reflex mechanism of the stapedius muscle enables the inner ear to rapidly prepare for the accident-induced high pressure sound
- Up to 40% reduction of noise exposure impact





10.25" Center Touchscreen Display (859)



10.25" Center Touchscreen Display (859)

Standard

Newly standard is a 10.25" widescreen high-resolution touchscreen display, perfect for operating all functions of the vehicle. The touchscreen operates in a smartphone-like fashion, responding to touch with accuracy and precision and with regular feedback consistent with what smartphone users expect out of a highly functional touchscreen.

Using navigation (optional), smartphone integration (standard), or simply setting any number of vehicle settings is now easier than ever before.



LED Headlamps (632) & LED Intelligent Light System (640)



LED Headlamps (632)

Standard

- Redesigned LED headlamps are now standard equipment improving the look of the standard GLC as well as providing increased safety due to brighter and higher quality headlamps.



LED Intelligent Light System (640)

Optional

- Redesigned headlamp incorporates updated technology and look for the GLC
- Ultra Wide Beam produces light at an increased width for maximum illumination of the road and surrounding area
- Adaptive Highbeam Assist is part of the LED Intelligent Light System and allows drivers to drive with highbeams activated at all times. System will automatically deactivate highbeams in the presence of oncoming traffic so as not to blind oncoming drivers.

Steering Wheel



3-spoke Nappa Leather Multifunction Steering Wheel
Standard



3-spoke Nappa Leather Sport Multifunction Steering Wheel
AMG Line

The newly redesigned 3-spoke multifunction steering wheel in nappa leather combines a sporty design, compact dimensions, and fine materials.

- Steering wheel shift paddles integrated into the back of the steering wheel cross spokes enable manual gear shifting and support a sporty driving style.
- Optional Active Distance Assist DISTRONIC® or standard cruise control is controlled via steering wheel-mounted controls.
- Touch Control buttons for direct control of the instrument cluster (analogue or digital) and to control the functions of the multimedia system.



Inductive Wireless Charging and NFC Pairing



Inductive Wireless Charging and NFC Pairing (897)

Option price: \$170

Driving time becomes charging time - with just a simple hand movement your smartphone can be fixed in place in the center console where it is charged wirelessly. Irrespective of the model and brand, all smartphones meeting the Qi standard are charged wirelessly.

Components:

- Wireless charging for numerous mobile phones that support or can be upgraded to support the Qi standard
- Quick establishment of connection between the multimedia system and mobile phone via Near Field Communication (NFC) for mobile device identification
- Charging area in the front tray in the center console for mobile devices





Digital Instrument Cluster



Digital Instrument Cluster (464) – Requires Multimedia Package (DA5)

Option price: \$750

For MY2019, the C-Class will now offer the option to have a high-resolution 12.3” digital instrument cluster with three different modes: Classic, Sport, and Progressive. Unlike many other models with this option, the C-Class integrates the digital instrument cluster within the dash so the geometry of the dash is the same as without the option.

The three separate modes allow the driver to customize the digital instrument cluster to his/her liking. Additionally, with the added digital space, there is greater functionality for navigation, multimedia, and other information within the digital instrument cluster itself.



Pictured Top: “Classic” design

Pictured Middle: “Sport” design

Pictured Bottom: “Progressive” design





Driver Assistance Package

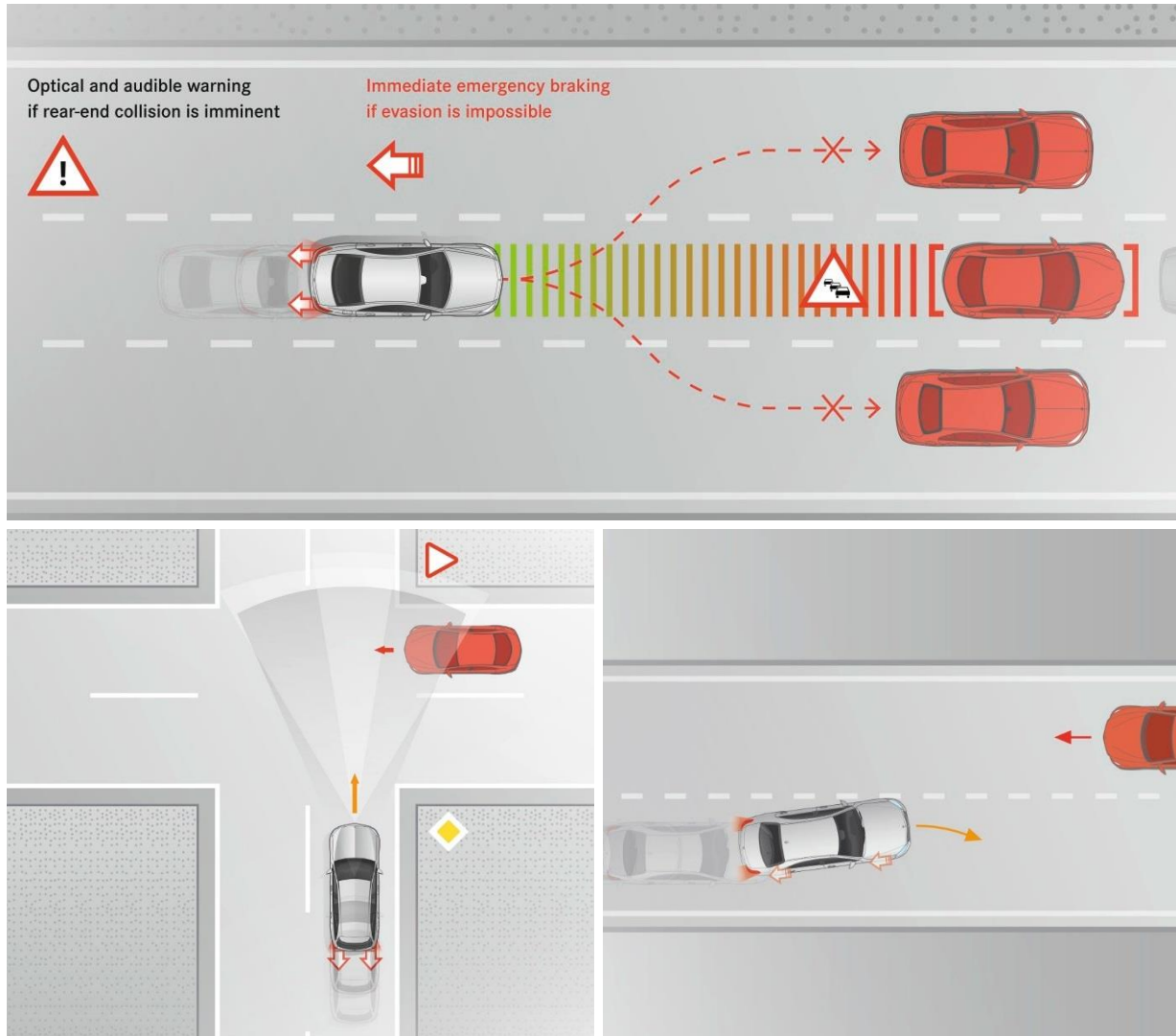

Driver Assistance Package (DA2)

Option price: \$2,250

- **Active Distance Assist DISTRONIC®** is able to follow a vehicle in front at a pre-selected distance at wider range of speeds
- **Active Steering Assist** functions at a wider range of speeds and can now actively intervene even if road lines are unclear or non-existent at certain speeds; can now function in curves with a tighter radius
- **Active Emergency Stop Assist** brakes the vehicle to a standstill in its lane if it detects that the driver is no longer actively driving the vehicle while it is on the move with Active Distance Assist DISTRONIC and Active Steering Assist engaged. Can now unlock the doors when the vehicle is stationary to allow first aid responders immediate access to the vehicle's interior. The system simultaneously makes an emergency call
- **Active Lane Change Assist** is a radar-and-camera-based system that aids the driver when changing lanes. When a turn is indicated, this feature will aid with steering into the adjacent lane if it detects the lane is empty
- **Active Speed Limit Assist** can adapt vehicle speed to identified speed limits and can now adjust preemptively when speed limits are going to change
- **Route-Based Speed Adaptation** the vehicle is now able to reduce the speed in anticipatory mode by referencing the COMAND map data ahead of bends, junctions, roundabouts, toll booths and exit roads.
- **Active Brake Assist with Cross-Traffic Function**
- **Evasive Steering Assist** this system assists by adding calculated steering torque to aid in steering wheel movement when a driver deliberately or instinctively performs an evasive maneuver around a pedestrian
- **Active Blind Spot Assist** is active at a wider range of speeds and informs the driver to help avoid an imminent side impact by single-sided braking
- **Active Lane Keeping Assist** is active now at a wider range of speeds



GLC 350e 4MATIC EQ Power



GLC 350e 4MATIC EQ Power

MSRP: To be Announced

For Model Year 2020, in addition to the considerable content added (upgraded technology, refreshed design, new standard options, new optional equipment), the GLC 350e 4MATIC EQ Power also receives a larger battery pack (8.7 kWh to 13.5 kWh) giving it more electric-only range (to be determined after EPA certification) and torque.

The benefits of considering a Plug-In Hybrid Vehicle are therefore greater than ever before, giving customers who have short commutes and/or run short errands the flexibility to save money through the use of electric-only range or supplemental energy to their regular Internal Combustion Engine.

Top Reasons Why a Customer May Consider a Plug-In Hybrid Vehicle (PHEV):

- PHEV technology enables unmatched versatility relative to internal combustion-only or electric-only vehicles
- Power from electric motor is far more economical than that of the gas engine (customers can save hundreds of dollars per year using PHEV technology)
- Federal, state, and local incentives may be available
- Only a slight daily routine adjustment required to attain the many benefits of the PHEV (plugging vehicle up to charge)
- Output and performance are superior than those of the GLC 300 4MATIC
- Driving in electric-only mode or hybrid mode gives peace of mind due to reduced emissions

Please note: due to technical requirements, AMG Line (DG3) and Night Package (DC1) are not available on the MY20 GLC 350e 4MATIC EQ Power



Performance & Handling

- 2.0L Inline-4 Turbo Engine
- 9G-TRONIC 9-Speed Automatic Transmission
- 4MATIC® Permanent All-Wheel Drive (GLC 300 4MATIC)
- ECO Start/Stop System
- DYNAMIC SELECT
- Independent Front/Rear Suspension

GLC 350e 4MATIC EQ Power specifications (additional/different from GLC 300 4MATIC):

- 2.0L Inline-4 Turbo Engine & 90kW Electric Motor
- Sport Perforated Front Brake Discs and Front Brake Calipers With “Mercedes-Benz” Lettering
- Radar-Based Regenerative Braking System
- J1772 AC Charging
- ECO-Assistant Haptic Accelerator Pedal

Comfort & Convenience

- MBUX intelligent vehicle assistant (“Hey Mercedes”)
- 10.25” center touchscreen display
- Heated Front Seats
- Power Front Seats with Driver Memory
- KEYLESS START
- Bluetooth® Technology (for Handsfree Phone Use/Audio Streaming)
- Two USB Ports
- Dual-Zone Automatic Climate Control
- Touchpad with haptic feedback
- Multifunction leather steering wheel w/ Touch Control Buttons
- HD Radio
- Frontbass® Audio System

- 4-way Lumbar Support
- Power Tilt & Telescoping Steering Column
- Electronic Cruise Control
- Power Windows with Express Up and Down
- Storage Package
- Garage Door Opener
- Intermittent Wipers with Rain Sensor
- Auto-Dimming Driver & Rearview Mirror
- Split-Folding Rear Seats (40/20/40)
- Power Liftgate
- Portable 110V Household Socket EV Charging Cable (GLC350e 4MATIC EQ Power)

Safety & Security

- New Vehicle 4 Year/50,000 Mile Warranty
- 24h Roadside Assistance Program
- Blind Spot Assist (234)
- LED Headlamps and Taillamps
- PRE-SAFE® now w/ PRE-SAFE Sound
- Active Brake Assist
- 3-point Seat Belt with Pretensioners & Dual-Stage Belt Force Limiter
- Front Dual-Stage Airbags

- Front and Rear Side Window Airbags
- Front Side Airbags
- Driver Kneebag
- Rearview Camera
- ISOFIX Anchor and Tether System
- ATTENTION ASSIST Driver Drowsiness Monitor
- Tire Pressure Monitoring System
- Anti-theft Alarm System





Non-metallic Paints

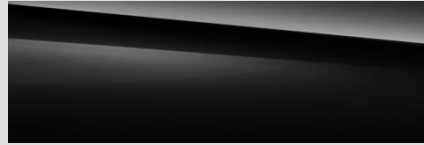

040
Black
Option price: \$0



149
Polar White
Option price: \$0

Metallic Paints



197
Obsidian Black
Option price: \$720



775
Iridium Silver
Option price: \$720



859
Mojave Silver
Option price: \$720

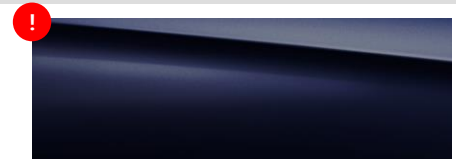

890
Lunar Blue
Option price: \$720



896
Brilliant Blue
Option price: \$720



992
Selenite Grey
Option price: \$720



831
Graphite Grey
Option Price: \$720

designo Paints



996
Cardinal Red Metallic
Option price: \$1,080



799
Diamond White Metallic
Option price: \$1,515



297
Selenite Grey Magno
Option Price: \$2,020



97R

18" Split 5-Spoke Wheels
R02, R66
Option Price \$0



R31

18" 5-Spoke Wheels
R02, R66
Option price: \$0



48R

19" 5-Spoke Wheels w/ Grey
Accents
R02, R66
Option price: \$500



R58

19" 10-Spoke Wheels
R02, R66
Option Price \$500



30R

20" Twin 5-Spoke Wheels
R01, R66
Option Price \$1,250



64R

18" Aero Alloy Wheel
R02, R66
Option price: \$200
GLC 350e 4MATIC EQ Power Only



15R

19" Aero Alloy Wheel
R02, R66
Option price: \$700
GLC 350e 4MATIC EQ Power Only



R39

19" 5-Spoke Wheels w/ Black
Accents
R02, R66
Option Price \$700





RTF

19" AMG Split 5-Spoke
R02, R66
Option price: \$0
Requires AMG Line (DG3)



RTG

19" AMG Split 5-Spoke, w/
Black Accents
R02, R66
Option price: \$0
Requires Night Package (DC1)



688

20" AMG Multispoke Wheels
R01, R66
Option price: \$750
Requires AMG Line (DG3)



698

20" AMG Multispoke Wheels, w/
Black Accents
R01, R66
Option price: \$750
Requires Night Package (DC1)



RZX

20" AMG Y 5-Spoke Wheels
(staggered)
R02, R66
Option price: \$750
Requires AMG Line (DG3)

Note: Since AMG Line (DG3) and Night Package (DC1) are not available with the GLC 350e 4MATIC EQ Power, these wheels only apply to the GLC 300 and GLC 300 4MATIC.





<i>Code</i>	<i>Wheel Size</i>	<i>Description</i>	<i>Wheel Dimensions</i>	<i>Mobility</i>	<i>Availability</i>	<i>MSRP</i>
97R	18"	Split 5-Spoke Wheels	235/60 R18 on 8 J x 18 ET 38	R02, R66	All models	\$ 0
R31	18"	5-Spoke Wheels	235/60 R18 on 8 J x 18 ET 38	R02, R66	All models	\$ 0
48R	19"	5-Spoke Wheels	235/55 R19 on 8 J x 19 ET 38	R02, R66	All models	\$ 500
R58	19"	10-Spoke Wheels	235/55 R19 on 8 J x 19 ET 38	R02, R66	All models	\$ 500
30R	20"	Twin 5-Spoke Wheels	255/45 R20 on 8.5 J x 20 ET 40	R01, R66	All models	\$ 1,250
R39	19"	5-Spoke Wheels w/ Black Accents	235/55 R19 on 8 J x 19 ET 38	R02, R66	All models	\$ 700
64R	18"	Aero Alloy Wheels	235/60 R18 on 8 J x 18 ET 38	R02, R66	GLC350e4	\$ 200
15R	19"	Aero Alloy Wheels	235/55 R19 on 8 J x 19 ET 38	R02, R66	GLC350e4	\$ 700





<i>Code</i>	<i>Wheel Size</i>	<i>Description</i>	<i>Wheel Dimensions</i>	<i>Mobility</i>	<i>Availability</i>	<i>MSRP</i>
RTF	19"	AMG Split 5-Spoke Wheels	235/55 R19 on 8.0 J x 19 ET 38	R02, R66	GLC300W/ GLC300W4	\$ 0 <i>Requires AMG Line (DG3)</i>
RTG	19"	AMG Split 5-Spoke Wheels w/ Black Accents	235/55 R19 on 8.0 J x 19 ET 38	R02, R66	GLC300W/ GLC300W4	\$ 0 <i>Requires Night Package (DC1)</i>
688	20"	AMG Multispoke Wheels	255/45 R20 on 8.5 J x 20 ET 40	R01, R66	GLC300W/ GLC300W4	\$ 750 <i>Requires AMG Line (DG3)</i>
698	20"	AMG Multispoke Wheels, w/ Black Accents	255/45 R20 on 8.5 J x 20 ET 40	R01, R66	GLC300W/ GLC300W4	\$ 750 <i>Requires Night Package (DC1)</i>
RZX	20"	AMG Y 5-Spoke Wheels (staggered)	255/45 R20 on 8.5 J x 20 ET 40 285/40 R20 on 8.5 J x 20 ET 40	R02, R66	GLC300W/ GLC300W4	\$ 750 <i>Requires AMG Line (DG3)</i>

Note: Since AMG Line (DG3) and Night Package (DC1) are not available with the GLC 350e 4MATIC EQ Power, these wheels only apply to the GLC 300 and GLC 300 4MATIC.



Interior Upholstery



101

Black MB-Tex

Option price: \$0

Not available with AMG Line (DG3)



115

Silk Beige/Black MB-Tex

Option price: \$0

Not available with AMG Line (DG3)



128

Magma Grey/Black MB-Tex

Option price: \$0

Not available with AMG Line (DG3)



221

Black Leather

Option Price: \$1,620

Not available with AMG Line (DG3)



228

Magma Grey/Black Leather

Option Price: \$1,620

Not available with AMG Line (DG3)



235

Silk Beige/Black Leather

Option Price: \$1,620

Not available with AMG Line (DG3)

Interior Upholstery – AMG Line



161

AMG Black MB-Tex

Option Price: \$0

Requires AMG Line (DG3)



197

AMG Cranberry Red/Black MB-Tex

Option Price: \$0

Requires AMG Line (DG3)



164

AMG Saddle Brown MB-Tex

Option Price: \$0

Requires AMG Line (DG3)



261

AMG Black Leather

Option Price: \$1,620

Requires AMG Line (DG3)



297

AMG Cranberry Red/Black Leather

Option Price: \$1,620

Requires AMG Line (DG3)



264

AMG Saddle Brown Leather

Option Price: \$1,620

Requires AMG Line (DG3)



Interior Upholstery – *designo* Nappa Leather



975

Platinum White Pearl/Black
Requires DD1 designo Package





51U

Black Fabric Headliner

Option price: \$0

Available with all upholsteries

Required by AMG Line (DG3) and designo Package (DD1)



55U

Porcelain Fabric Headliner

Option price: \$0

Available with Silk Beige/Black MB-Tex (115) or Silk Beige/Black Leather (235)

Not available with AMG Line (DG3) or designo Package (DD1)



58U

Crystal Grey Fabric Headliner

Option price: \$0

Available with Black MB-Tex (101), Black Leather (221), Magma Grey MB-Tex (128), or Magma Grey Leather (228)

Not available with AMG Line (DG3) or designo Package (DD1)





<i>Code</i>	<i>Upholstery</i>	<i>Seats</i>	<i>Floor Mats</i>	<i>Upper Dash/Lower Dash</i>	<i>Seat Belts</i>	<i>Steering Wheel</i>	<i>Headliner</i>
101	Black MB-Tex	Black	Black	Black	Black	Black	Black or Crystal Grey
115	Silk Beige/Black MB-Tex	Silk Beige	Black	Black/Silk Beige	Silk Beige	Black	Black or Porcelain
128	Magma Grey MB-Tex	Magma Grey	Black	Black	Black	Black	Black or Crystal Grey
161	AMG Black MB-Tex	Black	Black	Black	Black	Black	Black
164	AMG Saddle Brown MB-Tex	Black	Black	Black	Black	Black	Black
197	AMG Cranberry Red/Black MB-Tex	Black	Black	Black	Black	Black	Black
221	Black Leather	Black	Black	Black	Black	Black	Black or Crystal Grey
228	Magma Grey Leather	Magma Grey	Black	Black	Black	Black	Black or Crystal Grey
235	Silk Beige/Black Leather	Silk Beige	Black	Black/Silk Beige	Silk Beige	Black	Black or Porcelain
261	AMG Black Leather	Black	Black	Black	Black	Black	Black
264	AMG Saddle Brown Leather	Black	Black	Black	Black	Black	Black
297	AMG Cranberry Red/Black Leather	Black	Black	Black	Black	Black	Black
975	Platinum White Pearl/Black <i>designo</i> Nappa Leather	Two-Tone White/Black	Black with White Piping	Black	Black	Black	Black





H09

Natural Grain Brown Ash Wood

Option price: \$0



H07

Dark Brown Linden Wood

Option price: \$0

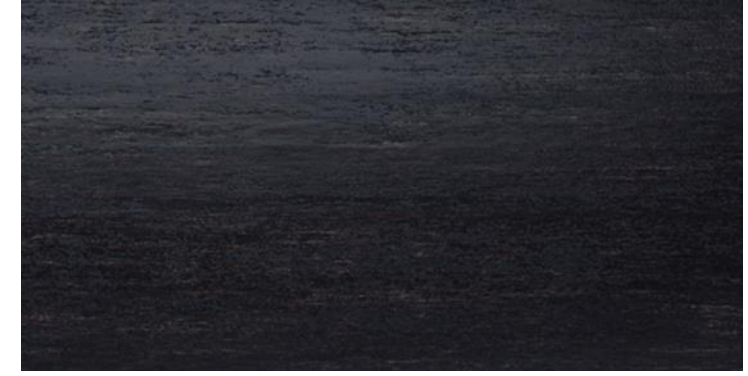

H31

Natural Grain Grey Oak

Option price: \$0



H33

Natural Grain Walnut Wood

Option price: \$0



737+739

Natural Grain Black Ash Wood with Aluminum Door
Trim

Option price: \$0





<i>Code</i>	<i>Packages</i>	<i>Availability</i>	<i>MSRP</i>
DP1	Premium Package <ul style="list-style-type: none"> ▪ 536 - SiriusXM® Satellite Radio ▪ 877+U25 - 64-Color Ambient Lighting & Illuminated Door Sills ▪ 889 - KEYLESS-GO® 	All Models	\$ 1,250
DA4	Exterior Lighting Package <ul style="list-style-type: none"> ▪ 640 - LED Intelligent Light System ▪ 608 - Adaptive Highbeam Assist 	All Models	\$ 900
DA5	Multimedia Package <ul style="list-style-type: none"> ▪ 549 - MBUX Premium Multimedia System ▪ 365 - MB Hard-Disc Navigation with Live Traffic ▪ 01U - Navigation Services ▪ U19 - Augmented Video for Navigation 	All Models	\$ 1,250
DA3	Parking Assistance Package <i>Requires Premium Package (DP1)</i> <ul style="list-style-type: none"> ▪ P17 - HANDS-FREE ACCESS ▪ P44 - Parking Package ▪ 235 - PARKTRONIC w/ Active Parking Assist ▪ 501 - Surround View System ▪ Rear Cross-Traffic Alert 	All Models	\$ 1,290





<i>Code</i>	<i>Packages</i>	<i>Availability</i>	<i>MSRP</i>
DA2	<p>Driver Assistance Package</p> <p><i>Requires Multimedia Package (DA5)</i></p> <ul style="list-style-type: none"> ▪ 23P – Driver Assistance Package Plus ▪ 233 – DISTRONIC PLUS with Steering Assist and Stop & Go Pilot ▪ 237 – Active Blind Spot Assist ▪ 238 – Active Lane Keeping Assist ▪ 253 – PRE-SAFE® PLUS ▪ 268 – BAS PLUS with Cross-Traffic Assist ▪ 300 – PRE-SAFE® Brake with Pedestrian Recognition ▪ Active Lane Change Assist ▪ Route-Based Speed Adaptation ▪ Active Speed Limit Assist ▪ Active Emergency Stop Assist 	All models	\$ 1,700
DG3	<p>AMG Line</p> <ul style="list-style-type: none"> ▪ 772 – AMG Line Body Styling ▪ P29 – AMG Line Interior ▪ P31 – AMG Line Exterior ▪ U26 – AMG Line Floor Mats* ▪ Flat-Bottom Multifunction Sport Steering Wheel <p><i>When ordered with P87 designo Black Nappa Leather package, flat-bottom steering wheel is replaced with round, smooth Nappa leather steering wheel</i></p> <ul style="list-style-type: none"> ▪ Front Sport Brakes with Perforated Discs and Mercedes-Benz lettered brake calipers ▪ Brushed Aluminum Pedals with Rubber Studs 	GLC 300 & GLC 300 4MATIC	\$ 1,600
DC1	<p>Night Package</p> <p><i>Requires AMG Line</i></p> <ul style="list-style-type: none"> ▪ P55 – High-Gloss Black Elements: Front wing, grille lamellas, rear diffuser insert, exterior mirrors, beltline and window trim ▪ 720 – Black Roof Rails 	GLC 300 & GLC 300 4MATIC	\$ 400





<i>Code</i>	<i>Packages</i>	<i>Availability</i>	<i>MSRP</i>
DD1	<p><i>designo</i> Two-Tone Platinum White Pearl / Black Nappa Leather Package</p> <p><i>Requires Natural Grain Black Ash wood center console with brushed aluminum door trim (737+739)</i></p> <ul style="list-style-type: none"> ▪ 975 - <i>designo</i> Platinum White Pearl / Black Two-Tone Nappa leather seats in diamond quilt design, with white contrast stitching, and <i>designo</i> badge on backrests of front and rear seats ▪ U04 - <i>designo</i> black floor mats with white border and <i>designo</i> badge in the front floor mats ▪ 51U - Black fabric headliner ▪ U09 - Dashboard and Upper Doors in MB-Tex with topstitching ▪ Additional Nappa leather and Nappa-look trim throughout cabin ▪ Flat-bottom sport multifunction steering wheel in black Nappa leather <i>Standard round steering wheel always replaced</i> 	All Models	\$ 3,800

Stand-Alone Options



<i>Code</i>	<i>Options</i>	<i>Availability</i>	<i>MSRP</i>
U09	MB-Tex Upper Dashboard with Topstitching <i>Included in designo Packages (DD1), Recommended for AMG Line (DG3)</i>	All Models	\$ 350
242	3-Position Memory for Passenger Seat with Adjustable Thigh Support	All Models	\$ 350
401	Ventilated Front Seats <i>Requires Leather Upholstery (not w/ 297)</i>	All Models	\$ 450
413	Panorama Sunroof	All Models	\$ 1,500
430	Off-Road Engineering Package	GLC 300 4MATIC	\$ 300
443	Heated Steering Wheel <i>AMG Line (DG3) and designo Platinum White Pearl/Black Nappa Leather (DD1) lose Flat-bottom Steering Wheel</i>	All Models	\$ 250
463	Head-Up Display	All Models	\$ 1,100
464	12.3" Digital Instrument Cluster	All Models	\$ 750
581	3-Zone Climate Control	All Models	\$ 760
550	Trailer Hitch – Class II Hitch	All Models	\$ 575
690	Emergency Spare Wheel	GLC 300 & GLC 300 4MATIC	\$ 200
810	Burmester® Surround Sound System <i>Recommended</i>	All Models	\$ 850
846	Brushed Aluminum Running Boards	All Models	\$ 650
851	Heat and Noise Insulating Front-Side Glass	All Models	\$ 150
872	Heated Rear Seats	All Models	\$ 580
897	Inductive Wireless Charging & NFC Pairing	All Models	\$ 200

Stand-Alone Options



<i>Code</i>	<i>VPC Installed Accessories</i>	<i>Availability</i>	<i>MSRP</i>
D03	Illuminated Star <i>Not available with Driver Assistance Package (DA2)</i>	GLC 300 / 300 4M	\$ 500
D07	Wheel Locks	All Models	\$ 150
D08	Chrome Door Handles	All Models	\$ 100
D11	Roof Spoiler	All Models	\$ 350
D12	Black Mirror Housing Covers <i>Not available with Carbon Fiber-look Mirror Housing Covers (D17) or Night Package (DC1)</i>	GLC 300 / 300 4M	\$ 250
D16	LED Logo Projectors	GLC 300 / 300 4M	\$ 200
D17	Carbon Fiber-look Mirror Housing Covers <i>Not available with Black Mirror Housing Covers (D12) or Night Package (DC1)</i>	GLC 300 / 300 4M	\$ 350
D18	Front Chrome Trim <i>Not available with AMG Line (DG3)</i>	All Models	\$ 250
D19	Rear Chrome Trim	All Models	\$ 200
D33	All-Weather Floor Mats	All Models	\$ 120



Headlamps



LED Headlamps (632)

Standard

- All functions feature LED technology
- Distinctive look by day and night
- Tail lamps with LED technology

Active LED Headlamps (640)

Only available with DA4 Exterior Lighting Package

All functions feature LED technology

- Automatically activated cornering lights
- Active light function for better illumination in bends
- Long service life due to LED technology - no need for bulb changes
- Light color similar to that of daylight
- Low energy consumption
- Tail lamps with LED technology
- Ultra Wide Beam increases high beam illumination to the sides



	<i>GLC 300</i>	<i>GLC 300 4MATIC</i>	<i>GLC 350e 4MATIC</i>
Engine Configuration	2.0L inline-4 turbo engine	2.0L inline-4 turbo engine	2.0L inline-4 turbo engine with 90kW Plug-in Hybrid Electric Motor
Power (hp)	255	255	315 combined / 121 electric
Torque (lb-ft)	273	273	516 combined / 295 electric
Displacement (cc)	1,991	1,991	1,991
Acceleration 0-60 mph (sec)	6.3	6.4	6.2
Electric Range (miles)	-	-	9
Charge Time, Wallbox (240v) / Home (110v) – 10-100%	-	-	TBD
Battery Size (kWh)	-	-	13.5
Fuel Economy (Cty/Hwy/Comb)	TBD	TBD	MPGe: TBD Gas-Only MPG: TBD
Top Speed (mph)	130	130	TBD
Fuel Requirement (Octane)	91	91	91
# Valves per cylinder	4	4	4
Compression	9.8 : 1	9.8 : 1	9.8 : 1
Transmission	9G-TRONIC	9G-TRONIC	9G-TRONIC
Transmission Speeds	9	9	9
Drive Configuration	Rear-Wheel Drive	All-Wheel Drive	All-Wheel Drive
Fuel Tank Size (gallons)	17.4	17.4	TBD
Trunk Size (cubic feet)	56.5	56.5	TBD
Curb Weight (lbs)	TBD	TBD	TBD
Vehicle Length (in.)	183.3	183.3	183.3
Vehicle Width w/ exterior mirrors (in.)	82.5	82.5	82.5
Vehicle Height (in.)	64.7	64.7	65.5
Wheelbase (in.)	113.1	113.1	113.1
Track Width Front/Rear (in.)	63.9/63.7	63.9/63.7	63.5/63.1
Coefficient of Drag (Cd)	0.31	0.31	0.35



Specifications* – GLC 300/GLC 300 4MATIC

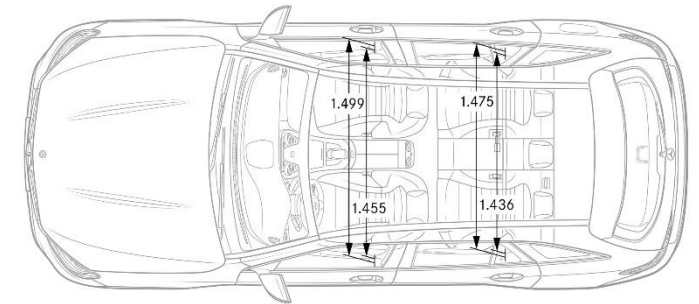
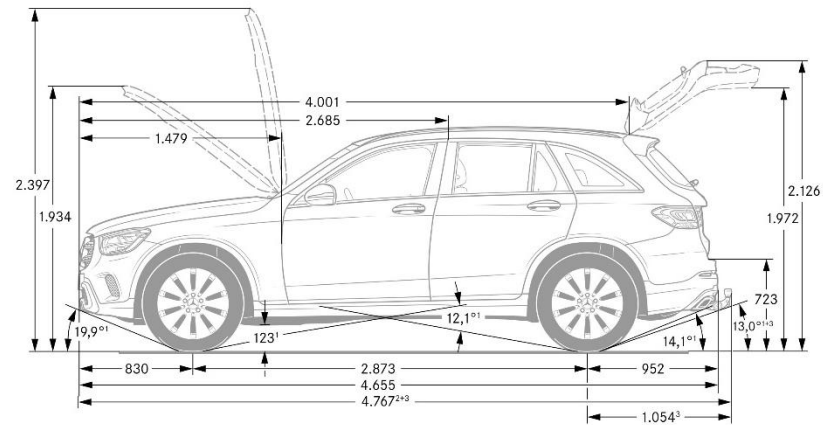
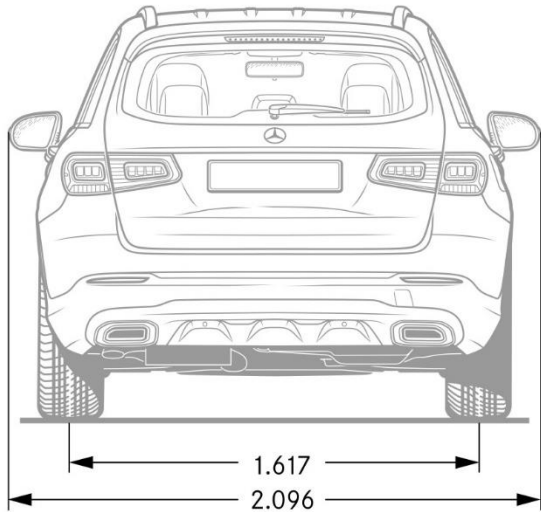
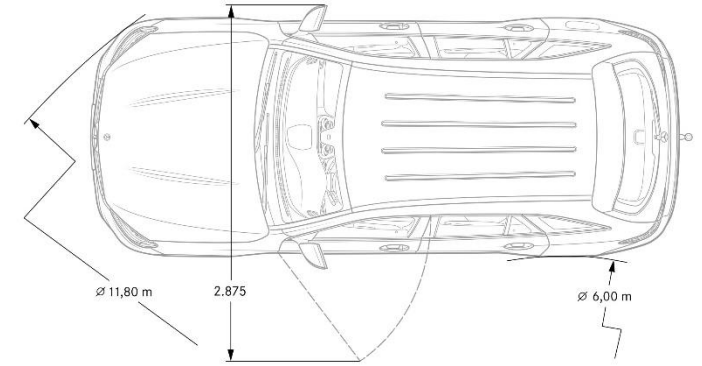
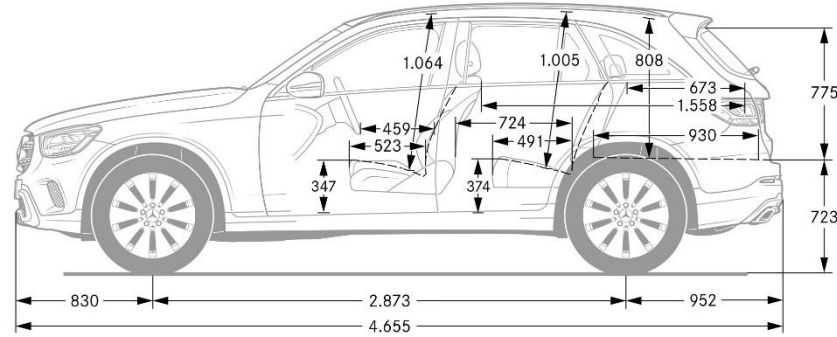
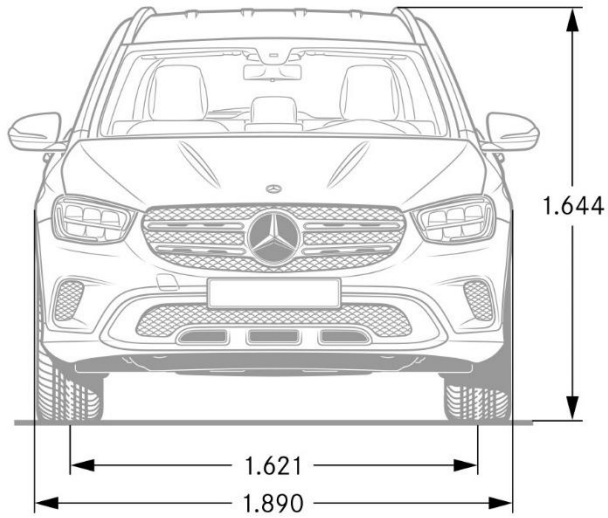

Specifications* – GLC 350e 4MATIC EQ Power

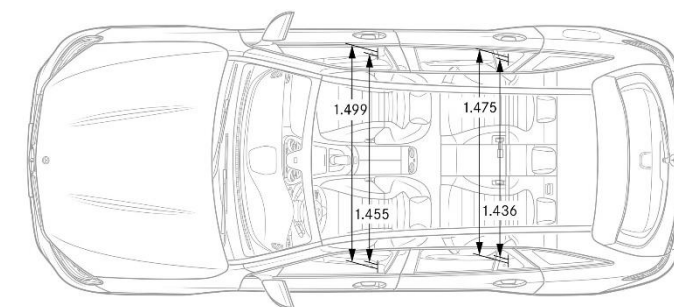
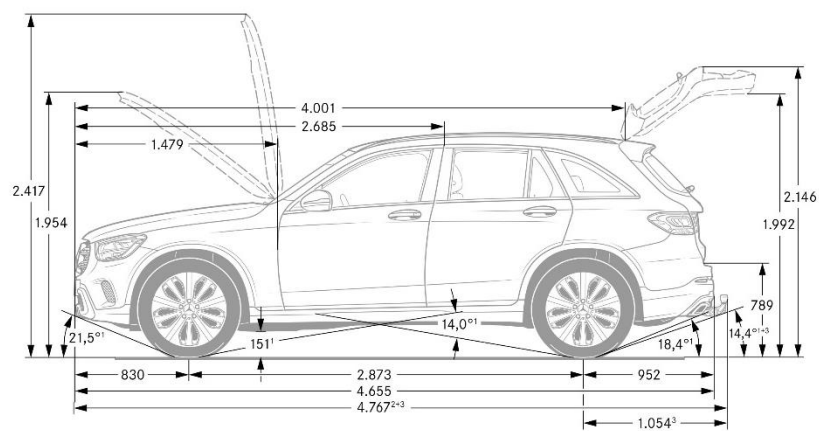
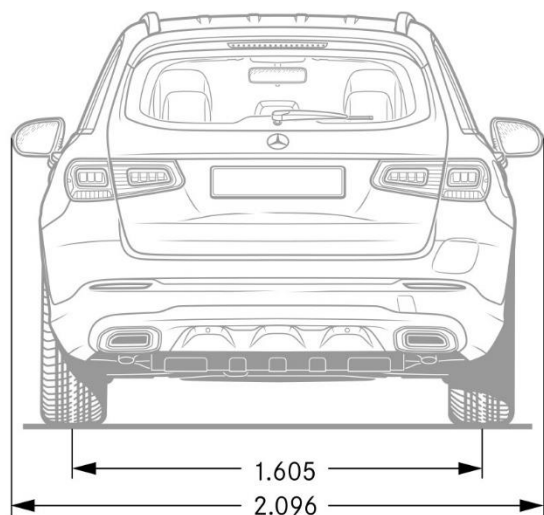
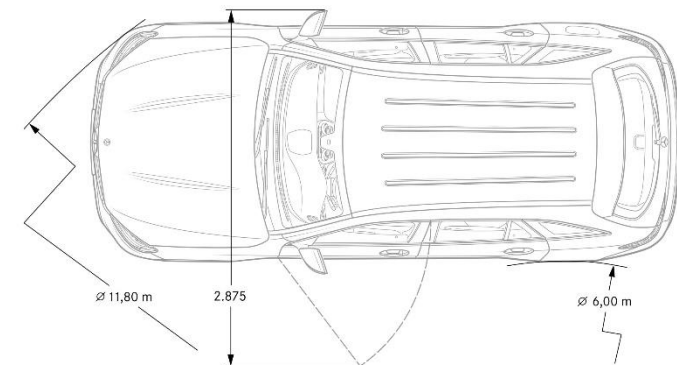
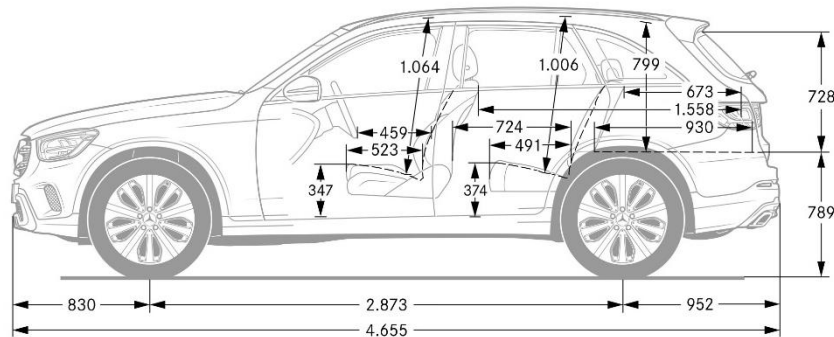
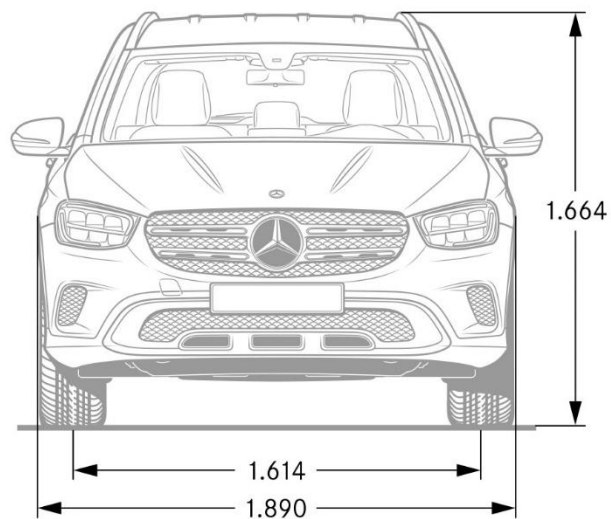

AMG GLC SUV



X253

Model Year 2020

Pricing Preliminary – Subject to Change

AMG
DRIVING PERFORMANCE

GLC63 4MATIC+



Models



What's new



Standard Equipment

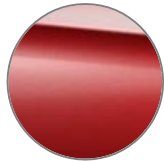

Exterior Paint Colors



Wheels



Interior Upholstery

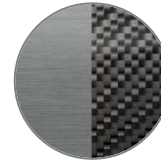

Interior Trims



Option Packages



Stand-Alone Options



Options in Detail



Build Recommendations

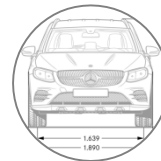

Specifications



AMG GLC 63 (253.988)

- MSRP \$73,750
- Handcrafted AMG 4.0L V8 biturbo engine
- 469 hp
- 479 lb-ft
- 3.8 sec (0-60 mph)
- Launch date: Q3 2019

Standard Equipment

- Facelift model
- NTG 6: New telematics generation incl. "Hey Mercedes"
- 10.25" multimedia touch screen and touchpad
- New front and rear bumpers
- LED headlights now standard on all AMG variants
- Slimmer LED headlights and new LED taillamp design
- New SUV tailpipe design
- Deletion of CD/DVD drive
- Upgraded AMG Performance steering wheel with haptic touchpads
- New key design
- Smartphone Integration now standard (Apple CarPlay™ and Android Auto)
- Electronic Limited Slip Differential
- 64-Color Ambient Lighting & AMG Illuminated Door Sills
- AMG Performance Exhaust System
- 12.3" Digital Instrument Cluster
- Multimedia Package including updated Navigation, Live Traffic, and new Augmented Reality

Optional Equipment

- New Package and Accessories codes to replace old codes
- New wheel designs
- AMG Track Pace (256)
- Deletion of Ski & Snowboard Bag (282)
- Inductive Wireless Charging with NFC Pairing (897)
- Pre-Wiring for Rear Seat Entertainment (866) no longer available
- Deletion of Light Brown Linden Wood trim (H24) and AMG Silver Fiberglass trim (H84)
- Natural Grain Grey Oak (H31) and Natural Grain Walnut Wood (H33) trims now available
- AMG Aerodynamics Package (B26) now available
- New steering wheel designs available
- AMG DRIVE UNIT (U88) now available on all steering wheels
- Deletion of 260/261 badge delete options

Packages

- Deletion of *designo* Black leather package (P87)
- New DE4/DE5 AMG Performance Seat Packages to get the AMG Performance Seats

Paint

- Graphite Grey Metallic (831) now available

Upholstery

- New upholstery in Magma Grey/Black with Yellow Accents

Performance & Handling

- Handcrafted AMG 4.0L V8 Biturbo (469 hp, 479 lb-ft torque)
- AMG RIDE CONTROL+ Sport Suspension
- AMG SPEEDSHIFT® MCT 9-Speed Transmission
- Electronic limited-slip differential
- AMG Performance 4MATIC+ (fully variable torque distribution)
- AMG High Performance Braking System
- AMG DYNAMIC SELECT
- 3-Stage ESP
- AMG Performance Exhaust System

Comfort & Convenience

- KEYLESS START & KEYLESS GO
- Power Folding Mirrors
- Burmester® Surround Sound System
- Bluetooth® Technology (for Handsfree Phone Use/Audio Streaming)
- SiriusXM Satellite Radio
- HD Radio
- Smartphone Integration (Apple CarPlay and Android Auto)
- Power Heated Front Seats with Driver Memory
- 4-way Lumbar Support
- Power Tilt & Telescoping Steering Column
- Electronic Cruise Control
- Power Windows with Express Up and Down
- Storage Package
- Heat and Noise Insulating Front-Side Dual-Pane Glass
- Touchpad with 10.25" Media Display
- 12.3" Digital Instrument Cluster
- Multimedia Package w/ Navigation, Live Traffic, and Augmented Reality
- AMG Performance Steering Wheel
- Dual-Zone Automatic Climate Control
- Garage Door Opener
- Intermittent Wipers with Rain Sensor
- Auto-Dimming Driver & Rearview Mirror
- Front and Rear Cupholders
- Split-Folding Rear Seats (40/20/40)
- Power Liftgate
- Automatic Headlamps with Twilight Sensor & Locator Lighting
- LED headlamps and taillights
- 115V AC Power Outlet
- 64-Color Ambient Lighting & AMG Illuminated Door Sills

Safety & Security

- New Vehicle 4 Year/50,000 Mile Warranty
- 24h Roadside Assistance Program
- 3-point Seat Belt with Pre-tensioners & Dual-Stage Belt Force Limiter
- Front Dual-Stage Airbags
- Front and Rear Side Window Airbags
- Front Side Airbags
- Driver Knee Airbag
- Rearview Camera
- ISOFIX Anchor and Tether System
- ATTENTION ASSIST Driver Drowsiness Monitor
- Active Brake Assist
- PRE-SAFE
- SmartKey with Panic Button
- Tire Pressure Monitoring System
- Anti-theft Alarm System
- Blind Spot Assist

Non-metallic Paints

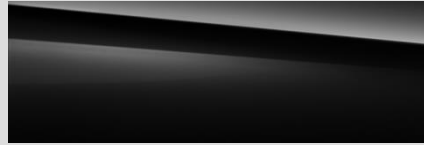

040
Black
Option price: \$0



149
Polar White
Option price: \$0

Metallic Paints



197
Obsidian Black
Option price: \$720



775
Iridium Silver
Option price: \$720



859
Mojave Silver
Option price: \$720



890
Lunar Blue
Option price: \$720
*Delayed until December 2019
production*



896
Brilliant Blue
Option price: \$720



992
Selenite Grey
Option price: \$720



831
Graphite Grey
Option price: \$720

designo[®] Paints



996
Cardinal Red
Option price: \$1,080



799
Diamond White
Option price: \$1,515



297
Selenite Grey Magno
Option price: \$2,020



RZS
20" AMG Twin 5-Spoke
R01, B51
\$0
Standard



RZT
20" AMG Twin 5-Spoke w/
Black Accents
R01, B51
\$200



RWK
21" AMG Multispoke
R01, B51
\$1,000



RWL
21" AMG Multispoke w/ Black
Accents
R01, B51
\$1,500

<i>Code</i>	<i>Wheel Size</i>	<i>Description</i>	<i>Wheel Dimensions</i>		<i>Mobility</i>	<i>Availability</i>	<i>MSRP</i>
RZS	20"	AMG Twin 5-spoke Wheel	265/45 R20 on 9.5 J x20 ET30 295/40 R20 on 10 J x20 ET28	Front Rear	R01, B51	GLC63	\$0
RZT	20"	AMG Twin 5-spoke Wheel w/ Black Accents	265/45 R20 on 9.5 J x20 ET30 295/40 R20 on 10 J x20 ET28	Front Rear	R01, B51	GLC63	\$200
RWK	21"	AMG Multispoke Wheel	265/45 R21 on 9.5 J x 21 ET30 295/40 R21 on 10 J x 21 ET28	Front Rear	R01, B51	GLC63	\$1,000
RWL	21"	AMG Multispoke Wheel, Black	265/45 R21 on 9.5 J x 21 ET30 295/40 R21 on 10 J x 21 ET28	Front Rear	R01, B51	GLC63	\$1,500





611

Black MB-TEX w / DINAMICA

Option price: \$0

*Also available with DE4 AMG Performance Seat
Package*

Not available with 401 Ventilated Seats

Interior Upholstery – Exclusive Nappa Leather



801

Black

Option price: \$2,590

Also available with AMG Performance Seats (DE5)



851

Platinum White Pearl/Black

Option price: \$2,590

Also available with AMG Performance Seats (DE5)

Shown here with DE5



857

Red Pepper/Black

Option price: \$2,590

Also available with AMG Performance Seats (DE5)

Shown here with DE5



858

Magma Grey/Black with Yellow Accents

Option price: \$2,590

Also available with AMG Performance Seats (DE5)

Shown here with DE5



DD1+965

Platinum White Pearl/Black

Option price: \$3,100

Also available with AMG Performance Seats (DE5)

<i>Code</i>	<i>Upholstery</i>	<i>Seats</i>	<i>Floor Mats</i>	<i>Upper Dash/Lower Dash</i>	<i>Seat Belts</i>	<i>Steering Wheel</i>	<i>Headliner</i>
611	Black MB-Tex/DINAMICA	Black	Black	Black	Black	Black	Black
801	Black Nappa	Black	Black	Black	Black	Black	Black
851	Platinum White Pearl/Black Nappa	Platinum White Pearl/Black	Black	Black	Black	Black	Black
857	Red Pepper/Black Nappa	Red Pepper/Black	Black	Black	Black	Black	Black
858	Magma Grey/Black Nappa w/ Yellow Accents	Magma Grey/Black	Black	Black	Black	Black	Black
965	<i>designo</i> Platinum White Pearl/Black Nappa	Platinum White Pearl/Black	Black	Black	Black	Black	Black



H07

Dark Brown Linden Wood
Option price: \$0



H31

Natural Grain Grey Oak
Option price: \$0



737+739

Natural Grain Black Ash Wood & Aluminum Trim
Option price: \$0



H73

AMG Carbon Fiber
Option price: \$975



H33

Natural Grain Walnut Wood
Option price: \$0

<i>Code</i>	<i>Packages</i>	<i>Availability</i>	<i>MSRP</i>
DA2	Driver Assistance Package <ul style="list-style-type: none"> ▪ 23P – Driver Assistance Package Plus ▪ 233 – DISTRONIC PLUS with Steering Assist and Stop & Go Pilot ▪ Active Blind Spot Assist ▪ Active Lane Keeping Assist ▪ PRE-SAFE® PLUS ▪ BAS PLUS with Cross-Traffic Assist ▪ PRE-SAFE® Brake with Pedestrian Recognition ▪ Active Lane Change Assist ▪ Route-Based Speed Adaptation ▪ Active Speed Limit Assist ▪ Active Emergency Stop Assist 		\$ 1,700
DA3	Parking Assistance Package <ul style="list-style-type: none"> ▪ P47 – Parking Package ▪ P17/871 – HANDS-FREE ACCESS Package ▪ 235 – PARKTRONIC w/ Active Parking Assist ▪ 501 – Surround View System ▪ Rear Cross-Traffic Alert 		\$ 1,290

<i>Code</i>	<i>Packages</i>	<i>Availability</i>	<i>MSRP</i>
DA4	Exterior Lighting Package <ul style="list-style-type: none"> ▪ 640 - LED Intelligent Light System ▪ 608 - Adaptive Highbeam Assist 		\$ 900
DC1	AMG Night Package <ul style="list-style-type: none"> ▪ Gloss black elements include A-Wing and front splitter trim, side sill inserts, rear diffuser trim, exterior mirror housings, window trim; roof rails in black; exhaust tailpipes in black chrome 		\$ 750
DC4	Exterior Carbon Fiber Package II <ul style="list-style-type: none"> ▪ AMG Exterior Mirror Housings 		\$ 1,200

<i>Code</i>	<i>Packages</i>	<i>Availability</i>	<i>MSRP</i>
DD1	<p>designo Platinum White Pearl/Black Nappa Leather Package</p> <p><i>Only available with 737+739 or H73 trims. If selecting Natural Grain Black Ash Wood, only need code 739 as 737 comes within the package already.</i></p> <ul style="list-style-type: none"> ▪ <i>designo</i> Platinum White Pearl / Black Two-Tone Nappa Leather seats in diamond quilt design with white contrast stitching ▪ Center door panels and armrests in Platinum White Pearl 		\$ 3,100
DE4	<p>AMG Performance Seat Package</p> <p><i>Only with 611 upholstery</i></p> <p><i>Not available in conjunction with 401 Ventilated Seats</i></p> <ul style="list-style-type: none"> • PBY - Control code • 555 - AMG Performance Seats 		\$ 2,500
DE5	<p>AMG Performance Seat Package Advanced</p> <p><i>Available on all leather upholsteries</i></p> <p><i>Not available in conjunction with 401 Ventilated Seats</i></p> <ul style="list-style-type: none"> • PBZ - Control code • 555 - AMG Performance Seats 		\$ 2,500

Stand-Alone Options



DRIVING PERFORMANCE

<i>Code</i>	<i>Options</i>	<i>MSRP</i>
B26	AMG Aerodynamics Package <i>Includes additional large front spoiler and larger rear diffuser w/ diffuser attachment</i> <i>Not available with 550 Class II Trailer Hitch</i>	\$ 1,400
U88	AMG DRIVE UNIT <i>Available on all steering wheels; Required with L6G</i>	\$ 400
U97	Spoiler Lip in High-Gloss Black <i>Only in conjunction with DC1 AMG Night Package</i>	\$ 350
256	AMG Track Pace	\$ 250
401	Heated and Ventilated Front Seats <i>Not with DE4 and DE5 packages</i>	\$ 450
413	Panorama Roof <i>Steel Roof is standard without sunroof</i>	\$ 1,500
463	Head-Up Display with AMG-specific Content	\$ 1,100
550	Class II Trailer Hitch <i>Not available with B26 AMG Aerodynamics Package</i>	\$ 575
581	3-Zone Automatic Climate Control	\$ 760
846	Brushed Aluminum Running Boards	\$ 650
872	Heated Rear Seats	\$ 580
897	Inductive Wireless Charging & NFC Pairing	\$ 200

<i>Code</i>	<i>VPC Installed Accessories</i>	<i>MSRP</i>
D03	Illuminated Star <i>Not with Driver's Assistance Package (DA2)</i>	\$ 500
D07	Wheel Locking Bolts	\$ 150
D08	Chrome Door Handle Inserts (set of four)	\$ 100
D11	Roof Spoiler	\$ 350
D12	Black Mirror Housings	\$ 250
D17	Carbon Fiber Look Exterior Mirror Covers <i>Not available with AMG Carbon Fiber Exterior Package (DC4) or AMG Night Package (DC1)</i>	\$ 350
D18	Front Chrome Trim	\$ 250
D19	Rear Chrome Trim	\$ 200
D32	LED AMG Crest Logo Projectors	\$ 275
D33	All Weather Floor Mats	\$ 120
<i>Code</i>	<i>Special Order Options (Additional Charge of \$250)</i>	<i>MSRP</i>
293	Rear Side Air Bags	\$ 420

Steering Wheels



AMG Performance Steering Wheel in Nappa (L6J)

Option price: \$0

Standard

For outstanding vehicle control, the AMG Performance steering wheel in Nappa leather features a flattened bottom section as well as perforated grip areas. The sporty design is completed by silver-colored aluminum shift paddles and a 12-o'clock marker.



AMG Performance Steering Wheel in Nappa/DINAMICA (L6K)

Option price: \$500

For even better grip during sporty maneuvers, the grip area on the AMG Performance steering wheel in Nappa leather is finished in DINAMICA microfiber. The steering wheel bezel comes in silver chrome with "AMG" lettering, silver-colored aluminum shift paddles and a 12-o'clock marker to round off the design.

Steering Wheels



AMG Performance Steering Wheel in DINAMICA (L6G)

Option price: \$600

Requires U88 AMG DRIVE UNIT



AMG Performance Steering Wheel in DINAMICA/Carbon Fiber (L6H)

Option price: \$900

Only available in combination with 737, 739, and H73 trims

AMG DRIVE UNIT (U88)



With the AMG steering wheel buttons you can make your steering wheel radically sporty: they allow fast, purposeful control of specific dynamic driving functions. For a focused, concentrated and performance-oriented driving sensation – and an authentic racing car atmosphere in the cockpit.

The AMG Performance steering wheels with AMG steering wheel buttons are reminiscent of Formula 1 steering wheels in terms of their operation and characteristics, and for good reason: thanks to the ergonomic positioning of the additional steering wheel buttons in the immediate grip area, you can keep your hands on the steering wheel at all times – thanks to the intuitively understandable functionality, you can always keep an eye on the road. Ideal prerequisites for challenging driving situations which require your full attention.

The individual steering wheel buttons are implemented as modern, mini displays. Pictograms on the buttons visualize the AMG-specific function which can be accessed in each case.

Components

- Two vertically positioned function displays **on the left** with rocker switch, Can be freely assigned AMG functions, for example for:
 - Direct selection of manual mode
 - Adjustment of the adaptive suspension
 - Activation/deactivation of the Electronic Stability Program (ESP®)
 - Switching of AMG Performance Exhaust System

- Function display **on the right** with round control knob:
 - Selection of drive programs and display of currently selected mode

AMG Track Pace (256)



AMG Track Pace transforms your AMG vehicle into your virtual race engineer. With the aid of lap, sector and acceleration times plus selected live telematics data you can analyze and improve your driving skill on cordoned-off tracks in a targeted manner.

In order to determine as precise a position as possible, AMG Track Pace works with a specially programmed algorithm which combines vehicle data such as wheel speed, steering angle and yaw rate with the satellite-aided GPS positioning system and updates every 50 milliseconds (20 Hz technology). This makes position measurement significantly more precise than with external applications such as third-party-provider apps on the smartphone.

In order to record and continually improve your individual performance, recorded data such as lateral and longitudinal acceleration, accelerator and brake pedal position or steering angle are used. All values are clearly depicted and can be read out directly in the vehicle. Fast or slow laps can be noted from the corner of the eye thanks to various color displays.

As well as recording drives on circuits or public routes, AMG Track Pace can also be used to record accelerations such as from standstill to 60mph or over a quarter mile plus deceleration values. Measurement with AMG Track Pace starts automatically when driving off or in deceleration mode when falling below a certain speed.

AMG Track Pace stores individual laps and sprints in the vehicle database. You can determine a reference time and compare your current drive with it – down to the last inch. This saves you any heavy and difficult-to-use additional equipment for analyzing your driving data.

The functions of AMG Track Pace are continually being improved and extended. You can find current information at www.mercedes-amg.com/track-pace.

Brakes



AMG High-Performance Braking System (B06)

6-piston front and single piston rear calipers

- Front axle: integral brake discs measuring 15.4 inch x 1.4 inch, internally ventilated and perforated with 6-piston fixed caliper
- Rear axle: brake discs measuring 14.2 x 1.0 inch, internally ventilated and perforated with 1-piston floating caliper
- grey-painted brake calipers with white AMG lettering
- Silver brake calipers



Build Recommendation for the GLC63 SUV

Model	GLC63 SUV	GLC63 SUV	GLC63 SUV
Baumuster	253988	253988	253988
Exterior Color	775 Iridium Silver Metallic	149 Polar White	831 Graphite Grey Metallic 858 Magma Grey/Black Nappa w/ Yellow Accents
Upholstery	611 Black MB-Tex/DINAMICA	851 Platinum White/Black Nappa	
Option Package	DC1 AMG Night Package	DA4 Exterior Lighting Package DA3 Parking Assistance Package	DA2 Driver Assistance Package DA3 Parking Assistance Package DC1 AMG Night Package
Wheel	RZT 20" AMG Twin 5-Spoke w/ Black Accents	RWK 21" AMG Multispoke	RWL 21" AMG Multispoke w/ Black Accents
Trim	737 Natural Grain Black Ash Wood/Aluminum	H31 Natural Grain Grey Oak	H73 AMG Carbon fiber
Standalone Options	413 Panorama Roof	413 Panorama Roof 401 Heated & Ventilated Front Seats 256 AMG Track Pace	413 Panorama Roof 401 Heated & Ventilated Front Seats 256 AMG Track Pace U88 AMG DRIVE UNIT L6G AMG Performance Steering Wheel in DINAMICA
MSRP Range	LOW	MEDIUM	HIGH

	<i>AMG GLC 63</i>
Engine Configuration	Handcrafted AMG 4.0L V8 biturbo engine
Power (hp)	469 @ 5,500-6,250 rpm
Torque (lb-ft)	479 @ 1,750-4,500 rpm
Displacement (cc)	3,982
Acceleration 0-60 mph (sec)	3.8
Fuel Economy (Cty/Hwy/Comb)	tbd
Top Speed (mph)	155 (lim.)
Fuel Requirement (Octane)	91
# Valves per cylinder	4
Compression	10.5 : 1
Transmission	AMG SPEEDSHIFT® MCT 9-Speed
Transmission Speeds	9
Drive Configuration	4MATIC+ Variable All-Wheel Drive
Fuel Tank Size (gallons)	17.4
Luggage capacity beh. front seats (cubic feet)	40.6
Curb Weight (lbs)	4,486
Vehicle Length (in.)	184.3
Vehicle Width w/ exterior mirrors (in.)	82.5
Vehicle Height (in.)	64.0
Wheelbase (in.)	113.1
Track Width Front/Rear (in.)	65.5/65.1

Specifications* – GLC 63 SUV

